



P.O. Box 1800, 31 Patterson Rd.
Barrie, Ontario, Canada L4M 4V3
Telephone: (705) 726-3381
Fax: (705) 726-8991
Website: www.canplas.com
E-mail: vaculine@canplas.com



“PUSH-FIT” PLASTER GUARD P/N 765543BLK

- Push-Fit design permits guard to be installed with or without screws
- Corner marking posts clearly indicate size of product on drywall/ sheet rock
- Inverted finger hold position makes it easy to insert guard to mounting plate
- Black color provides good visibility for product.

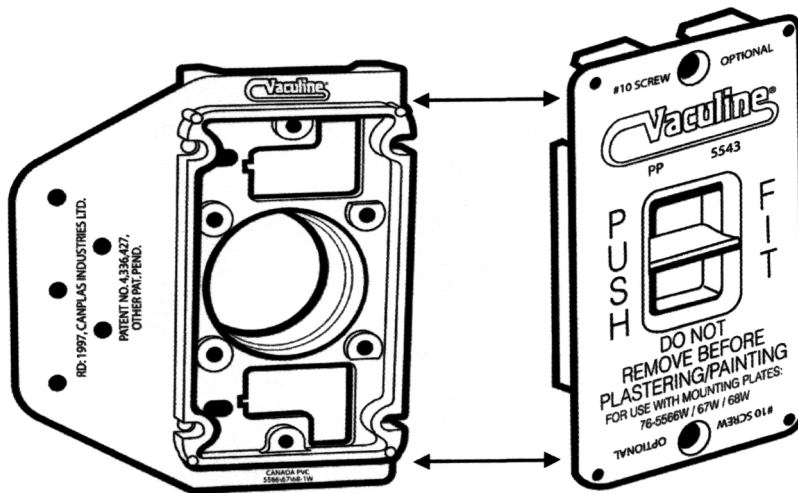

Ralph Guinn
Product Manager

March, 2004

MARKETING ANNOUNCEMENT

an *O*Aliaxis company